

252 & 10252 TRAINING WHEEL ASSEMBLY

IMPORTANT : USE THESE ASSEMBLY INSTRUCTIONS

ASSEMBLY INSTRUCTIONS :

1. ASSEMBLE WHEEL TO BRACKET AS ILLUSTRATED. TIGHTEN NUT SECURELY.
2. REMOVE REAR AXLE NUT FROM BIKE, ONE SIDE ONLY. (LEAVE LOCKING WASHER, IF SO EQUIPPED, ON AXLE NEXT TO BIKE FRAME).
3. PLACE BRACE ARM ON AXLE WITH OPEN SLOT AROUND BIKE FRAME AND MOUNT WHEEL-BRACKET ASSEMBLY TO REAR AXLE.

NOTE : IF NEEDED, PLACE HEAVY SPACER WASHERS ON REAR AXLE SO THAT BRACE ARM AND/OR BRACKET WILL CLEAR ANY OBSTRUCTIONS ON THE BIKE FRAME.

4. REPLACE AXLE NUT, ADJUST WHEEL TO 1/2" FROM GROUND AND TIGHTEN NUT SECURELY.
5. REPEAT FOR OTHER SIDE.

© WALD LLC 2007

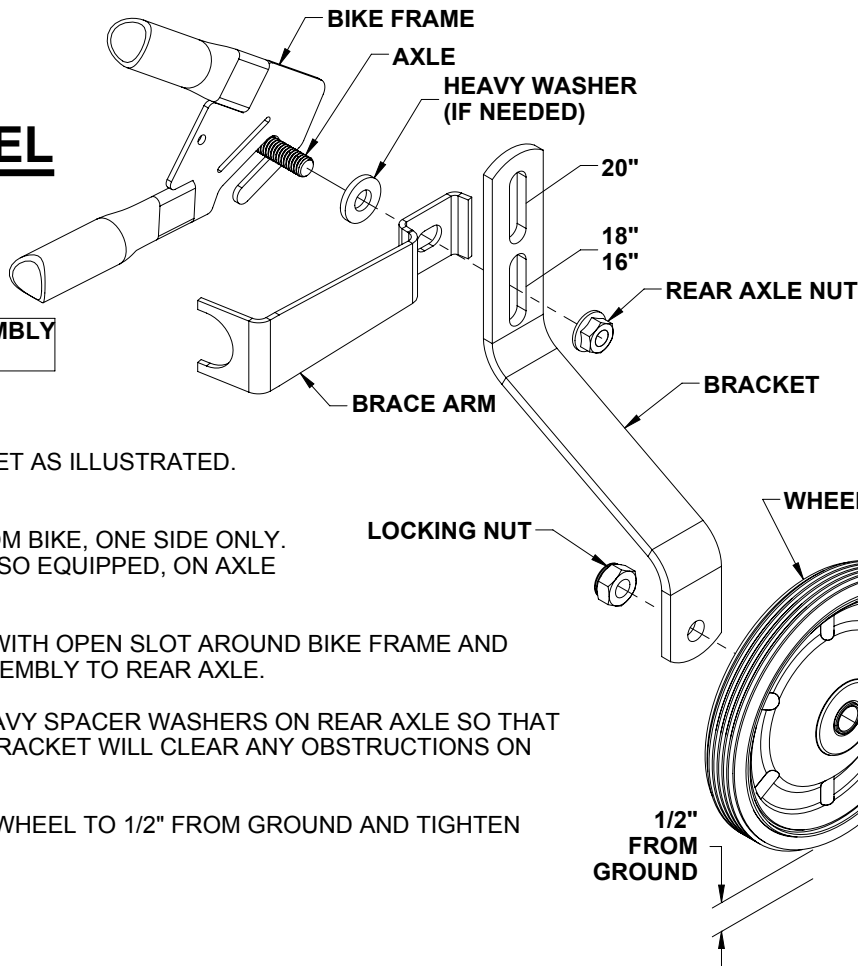

NO REV.