

BICYCLE DELIVERY BASKET

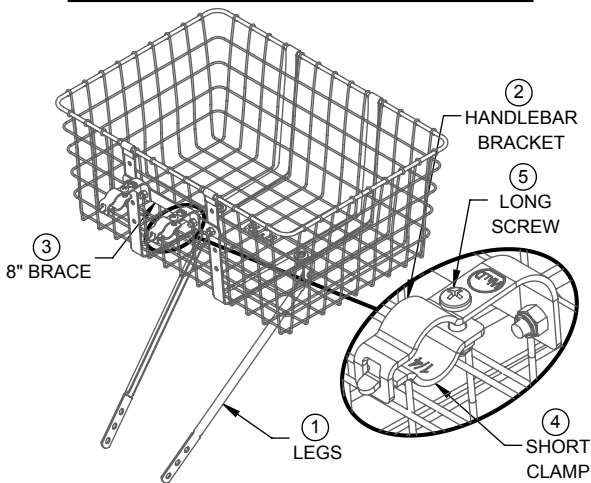

Assembly Instructions :

IMPORTANT : Flat washers must be used under all SHORT screw heads.

- Fasten ① legs to basket with short screws (use flat washer under screw head).
- ② Handlebar brackets are mounted to center holes on ③ 8" brace with short screws (use flat washer under screw head).
- Attach ③ 8" brace to bands on basket with short screws (use flat washer under screw head). Note : Use top holes for 26" bike.
- Fasten basket to handlebar with ④ short clamps using ⑤ long screws (Flat washers not required). If clamping onto 7/8" portion of handlebar, insert rubber spacer strips between handlebar brackets / short clamps and handlebar.
- Remove front axle nut and assemble basket leg to axle. Replace nut and tighten securely. Repeat for other side.
- Completely tighten all screws & nuts.

⚠ WARNING!

- **DO NOT** overload basket. Overloading basket may cause difficulty in steering and/or loss of bicycle control which could result in injury.
- See other side.



Mfgr. No. 157B

© WALD LLC 2009
REV.B 3/25/2009

WARNING!

- **DO NOT** bend legs or leg mounting tabs.
- **DO NOT** mount legs to the inside of the bicycle's front fork blades. Mount only to the outside of the bicycle's front fork blades.
- **DO NOT** use on bicycles with quick release front hubs. The legs are to be mounted to bolt on front axles.
- **DO NOT** use on bicycles with a carbon fiber front fork or handlebar.
- **DO NOT** use on bicycles with a front suspension or springer fork.
- Failure to tighten basket screws & nuts or wheel axle nuts, could result in loss of control & possible injury. Please consult a bicycle dealer or your bicycle owner's manual for applicable tightening/adjusting requirements.